

Levelpro LDS-YN Industrial Series is an advanced all plastic corrosion resistant leak detection /liquid level sensor that utilizes ultra-sensitive electrostatic technology which constantly and accurately senses the presence of liquids. These sensors are ideally suited for monitoring the interstitial area between double wall tanks, tank retention dikes, secondary containment sumps, and are as where process pumps and valves are utilized. The **LDS-YN** sensor has been engineered to withstand even the most extreme conditions while including features designed to optimize performance and reduce maintenance.

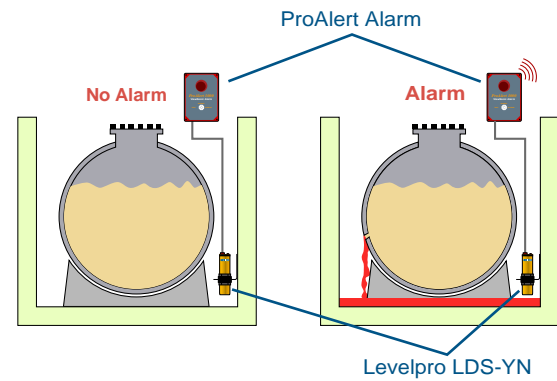

Wiring Diagram

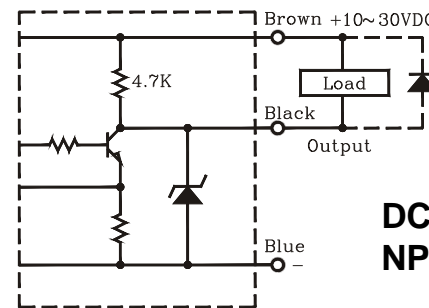

DC Powered NPN Relay Mode



FEATURES

- Suitable for Corrosive
- Environments Visual LED Light
- PP Plastic Body
- Non-Contact Technology

Dimensions

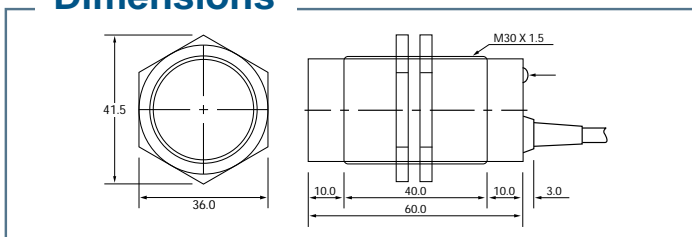

SPECIFICATIONS

Operating voltage	10-30VDC
Current consumption	20mA max.
Response frequency	100Hz
Output current	15mA max.
Leakage current	0.8mA max.
Residual voltage	0.8V max.
Protection circuit	Short Circuit & Polarity Reversed
Target	Presence of Liquid Liquid Level
Operating circumstance	-25 C - +80 C 35% - 95%RH
Case Dimension	General Purpose
Output status	NO NC
Output method	NPN PNP Relay Output
Sensing distance	20.0 mm
Visual Indication	LED
Sensitivity adjuster	14 Turns Trimmer
Housing material	PP

ORDERING

Part Number	Material
LDS-YN	PP